

(No Model.)

2 Sheets—Sheet 1.

F. W. TAYLOR. BORING BAR PUPPET.

No. 428,703.

Patented May 27, 1890.

FIG. 1.

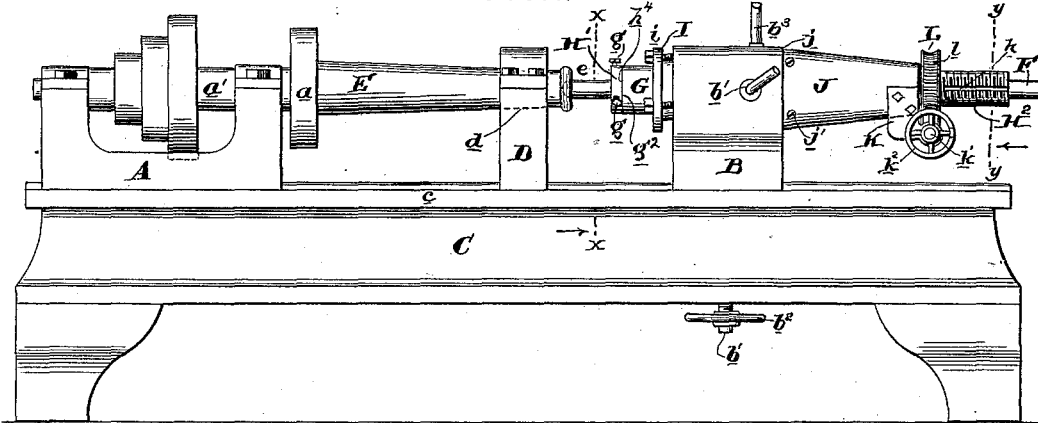

FIG. 2.

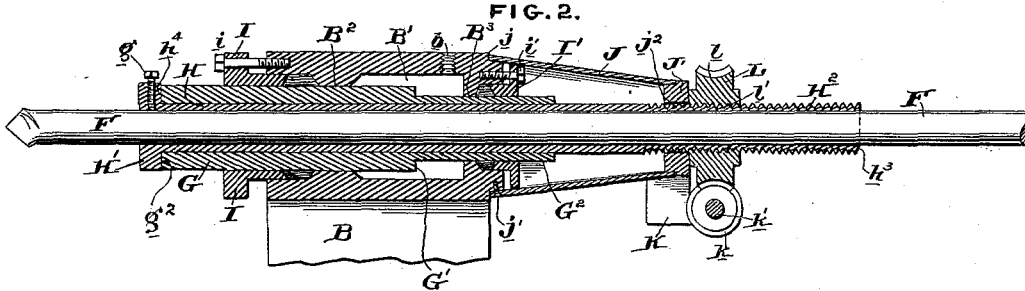

FIG. 3.

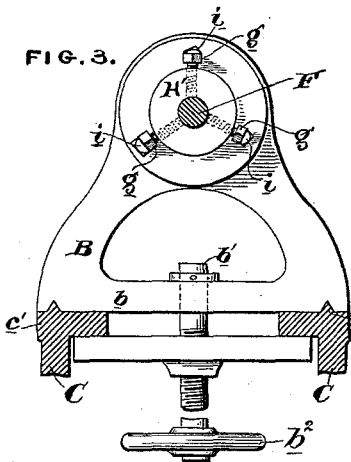
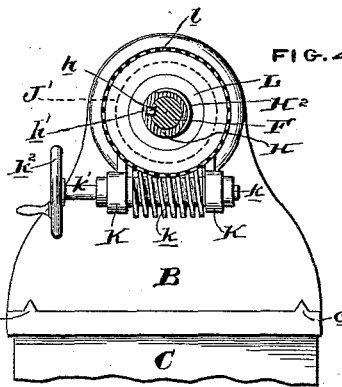

FIG. 4.



WITNESSES:

David S. Williams
Henry Dimey

INVENTOR:

Frederick W. Taylor,
by his attorney,
H. W. Ham Poul.

F. W. TAYLOR.
BORING BAR PUPPET.

No. 428,703.

Patented May 27, 1890.

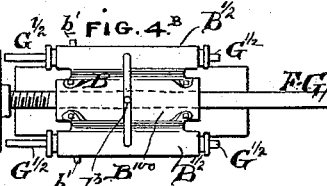
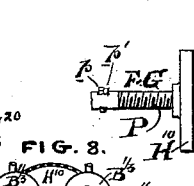
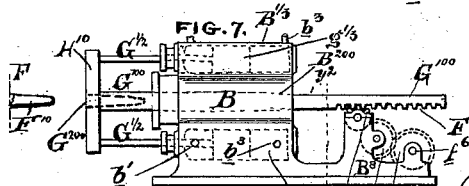
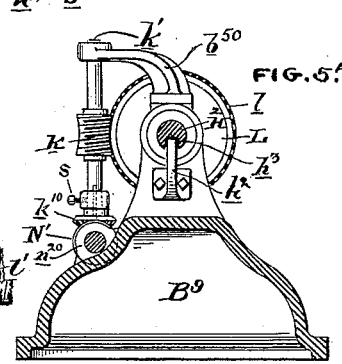
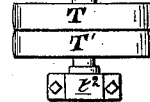
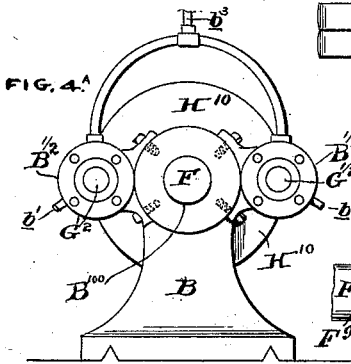
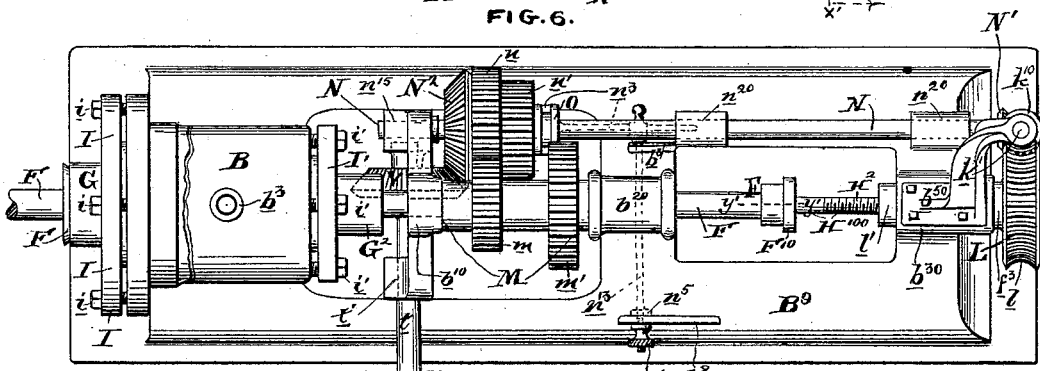
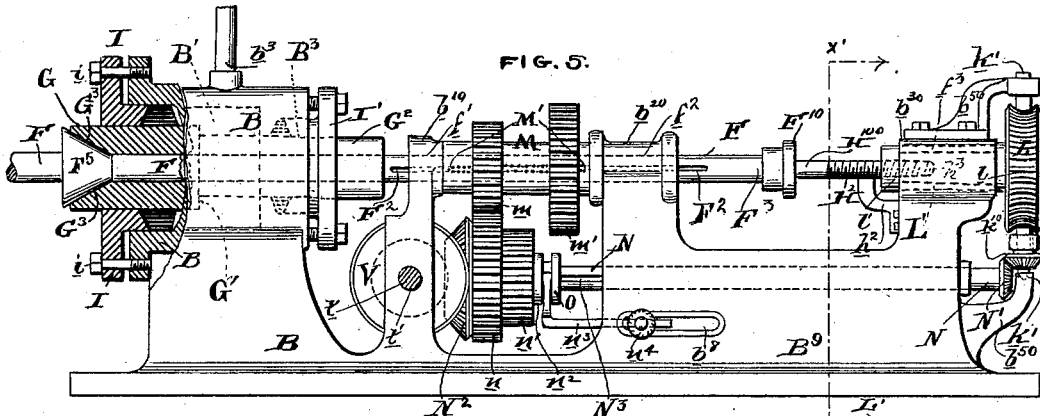

WITNESSES: David S. Williams
John T. Lewis

INVENTOR:
Frederick W. Taylor,
By his Attorney
H. O. Stan Paul.

UNITED STATES PATENT OFFICE.

FREDERICK W. TAYLOR, OF PHILADELPHIA, PENNSYLVANIA.

BORING-BAR PUPPET.

SPECIFICATION forming part of Letters Patent No. 428,703, dated May 27, 1890.

Application filed September 27, 1889. Serial No. 325,248. (No model.)

To all whom it may concern:

Be it known that I, FREDERICK W. TAYLOR, of the city and county of Philadelphia, State of Pennsylvania, have invented a new and useful Improvement in Boring-Bar Puppets, of which the following is a specification.

My invention relates especially to that class of puppets or "tail-stocks" which are used upon lathes of considerable size to advance a boring-bar into the axis of a piece of revolving work, but it being also well adapted as a puppet for use in conjunction with lathe-carriages, planer cross-heads, upright drills, &c., and for advancing revolving as well as rectilinearly-reciprocating boring-bars into radial and other holes, it is hereinafter particularly described in connection with the adjustable tail-stock of a power-lathe as illustrative rather than as limitative of its use and scope.

The chief object of my present invention is in advancing a boring-bar by a hydraulic-ram system, to do so with a compact mechanism disposed radially and systematically about the bar, the whole located so as to be as close to the cutters of the bar or its support as is compatible with the mechanism's range of action, and preferably constituted of concentrically-enveloping elements, further objects being to combine with a hydraulic boring-bar mechanism such further mechanism as may either prohibit or control the rate of advance which the thrusts of the hydraulic ram or rams may tend to deliver upon the boring-bar, (in which connection I hereby refer for further information as to this method of feeding when the advancing and restraining forces are applied out of a common alignment to my United States patent, No. 289,121, dated July 31, 1888;) also, to contrive the mechanism so that by taking one or more fresh holds upon the bar its advance may be continued through a range of action greater than that of the working-stroke of the hydraulic ram or rams, together with such other novel features as I distinguish in the following description and claims. For reference now being had to the accompanying drawings, forming part of this specification, in which similar letters of reference indicate corresponding parts throughout the figures, they will be found to illustrate my invention, as follows, to wit:

Figure 1 is a side elevation of a power-lathe equipped with a "back-rest" and my improved boring-bar-puppet mechanism in the act of feeding a reciprocating boring-bar into the axis of a piece of chucked work; Fig. 2, a longitudinal median cross-section of the puppet mechanism shown in Fig. 1, the foot or supporting part being broken away for the sake of economy of space; Figs. 3 and 4, front and rear views, respectively, of the puppet-head shown in the above figures, the line xx , Fig. 1, denoting that of the cross-section of Fig. 3, and the line yy that on which the section of Fig. 4 was made; Figs. 4^A and 4^B, rear and plan views of a modification upon a duplex arrangement, the scale being considerably greater in Fig. 4^A; Figs. 5 and 6, a side elevation and plan view, respectively, of a modification of my improved puppet applicable for rotating boring bar or drill; Fig. 5^A, an endwise view, partially in section, looking outward to the rear, as indicated in offset arrow ends of the broken line $x'x'$ of the structure shown in Fig. 5; Fig. 5^B, a detail of a fragment on an enlarged scale, the portion given sectionally being indicated by the broken sectional line $y'y'$ of Fig. 6; Figs. 7 and 8, a side elevation and rear end view of a further modification.

In the figures, A represents the live-head of a power-lathe, of which the shears C are fashioned with ordinary prismatic guide-rails cc' , Figs. 1 and 3, and carry a back-rest or boring-collar D. The work E, carried by the chuck a , finding a concentric bearing in the collar d of this rest D, presents its free or muzzle end e to the boring-bar F. Now this bar F enveloped in a concentric sleeve, the bushing H (see Figs. 2 and 4) issues from the muzzle or front end of the tubular puppet-slide G, the whole lying concentrically disposed to and in the prolongation of the axis of the mandrel d' , and the slide G finding an abutment for its muzzle g^2 against the adjoining face h^4 of the chuck-flange collar H' of the bushing H, whose radial screws $g g$ serve to grip and fix at any desired portion of its length the shank of said centrally-disposed boring-bar F, which bar is also so fitted to this bushing that without loss of alignment it can slide freely endwise through the same. So, too, the circular neck-orifices B² B³ of the

puppet-head housing B and their packing-glands I I', (see Figs. 2 and 5,) adjustably bolted to the front and rear of said housing B, (by the bolts $i i'$), fitting closely about the front and reduced tail G and G² of this slide G, serve to keep it and the parts it carries not only in its aforesaid alignment with great steadiness and accuracy, but also to allow it to reciprocate longitudinally with tight joints in the necks aforesaid, the length of stroke being approximately the length of the internal cylinder-cavity B' of the housing aforesaid, and the flange or annular surface G' between the front and rear extensions of the slide G forming in the preferred enveloping single-cylinder sort (illustrated in Figs. 1 to 4, inclusive) the piston area d , upon which water or other equivalent liquid when introduced under pressure by suitable supply and escape conduits—such as the pipes $b' b^2$, screwed into holes, as b , Fig. 1, communicating with the cylinder-cavity B'—acts to urge the slide G as a ram outward from the body of B toward the work E. Thus with the puppet slide-bar G, by the pressure transmitted from its muzzle as a ram through the collar H' and chuck-screws $g g g$, (or their equivalent,) the bar F and the tubular bushing H also receive a tendency to similarly advance toward the work, and this tendency to advance under the hydraulic pressure in the endwise-sliding parts of the above-described device (illustrated in Figs. 1 to 4, inclusive) the screw-threaded tail H² of the bushing H and its nut L either prohibits or controls.

It is evident that the bushing H may be made integral with and part of the slide-bar G, instead of being detachable therefrom, in which case the screw-threaded tail H² of the bushing H would be part of the slide-bar G. Said threaded tail H² of the bushing H, (see Fig. 1,) while splined, so as to prevent rotary motion by the slot h (fashioned integral therein) and the key h' , seated in the collar J', (see Figs. 1 and 4,) otherwise passes freely endwise through the collar, which in turn, being fashioned integral with the casing J, is secured together with it (J) by the latter being abutted and fixed, as by screws j' , to the annular shoulder j of the housing B, (see j , Fig. 1,) whereby the whole, forming a concentric cap to the rear of stuffing-box I', reacts to the strains which the advancing tendency of the ram aforesaid transmits through the various sliding parts to the nut L, and it (L) when stationary delivers these strains through J J' to the said shoulder j , and thereby the housing B on receipt absorbs them, while, on the other hand, any unscrewing or running down of the nut L toward the free end h^2 , Fig. 2, of the tail H², naturally acting to release H, permits the tendency aforesaid to develop into an actual advance of the slide-bar G, and with it H H', $g g g$, and F are fed forward toward the work. Now these conditions of the nut L are conveniently regulated by me as follows: The screw H (being slotted lengthwise, as above

described and shown at h , Fig. 1,) carries the nut L, when banked against the rear of the abutment-collar J, with the worm-teeth l , that are cut upon that nut's concave periphery in gear with the threads of the "tangent screw" l , journaled transversely to the axis of said nut L in a suitable position by the bracket-bearings K K, and thus the worm-screw's spindle l' affords by its fixed cranked hand-wheel l^2 a convenient means for manually actuating this as a releasing mechanism, as well as an automatic hold-fast preventive of its nut's rotation if left by the operator at any desired adjustment along the threaded portion H² of the sliding bushing H. Moreover, in cases where means for forcibly exhausting the liquid introduced into the cavity B' do not exist, the nut L and screw H² are in themselves readily available as a device for withdrawing the protruded portions of the sliding members G H and whatever bar F, &c., they may have chucked to carry; but of course to this end the fluid in the cylinder-cavity B' must not only be released from pressure, but allowed to escape, which can be accomplished by the conduit b^3 . Otherwise by exhausting the fluid, &c., from the cavity B' the pressure of the air upon the muzzle area of the ram-plunger or piston-rod may be called on to act to force the sliding parts home after a protrusion, the nut L being then merely run along the tail H² at a proper pace to permit of the consequent retreat.

The slide-bar G may be, as is often the case in ordinary lathe-puppets, prismatic instead of cylindrical, (see G¹⁰⁰, Figs. 7 and 8,) wherein it is illustrated as of square cross-section, and it then may be equipped with a longitudinally-disposed rack F²⁰, and a spur and pinion wheel train F³⁰ F⁴⁰ F⁵⁰, rotatably journaled in a suitable housing formed by an extension B⁸ of the main puppet-housing B, (see Fig. 7,) the crank-handle of which train f^5 , fixed to the spur-wheel shaft f^8 , Fig. 8, to which it is offset as a fragment, serving to control the slide-bar in releasing, restraining, or retreating the mechanism instead of the preferred screw and the nut-releasing device shown in Figs. 1, 2, and 4; but should this "releasing" method of feeding not be desirable in certain cases, it is within the purview of my present invention not to employ one, as, say, by using, first, such a device as that illustrated in Fig. 1, divested of the abutment tail-case J, together with all the holdback mechanism—such as the worm-screw l , the nut L, and the screw H²—to which end the removal of the bolts j' and nut L in the instance under consideration suffices, and that being done the reciprocations of the puppet-slide G are to be effected, whether for actual feeding or for mere retreating, &c., by the pressing into or exhausting from it of the liquids within the cylinder-cavity B' by way of the conduits $b^2 b^3$; second, such a device as that illustrated in Figs. 4^A 4^B, wherein the mechanism, apart from certain structural modifications not

shown in Figs. 1 to 4 or 7 and 8, is primarily constructed without any releasing mechanism, for, in addition to the above concentric enveloping forms, Figs. 4^A 4^B show a modification, consisting of a duplex-ram system, to wit: the right and left similar and symmetrical ram-cylinders $B\frac{1}{2} B\frac{1}{2}$, bolted upon, lying parallel to, and at equal distances from the central puppet slide-bar F G, which, passing through a cylindrical guide-chamber B¹⁰⁰, (as an ordinary lathe-puppet's slide-bar does,) is here adapted to be actuated endwise by the piston-plungers $G\frac{1}{2} G\frac{1}{2}$, which, issuing from the aforesaid cylinders, bear upon diametrically-opposite portions of the annular collar H¹⁰, Fig. 7, and that collar being mounted, preferably, so as to be longitudinally adjustable endwise along the screw P of the slide-bar F G, it serves to transmit the thrusts of these rams evenly and simultaneously to it. Moreover, as the bar F G in this case carries the cutter *p*, keyed by wedge *p'*, in a suitable transverse slot near its outer end, it very clearly illustrates the close association which my invention permits between the tool, the guided portion of the now integral boring slide-bar, and the forcing agent or ram system, and this despite the fact that the aforesaid ram-cylinders $B\frac{1}{2}$ are also in this instance shown as separable parts bolted to the sides of B.

So Figs. 7 and 8 display a still further modification without departure from the typical radial disposition, for, in addition to a square slide-bar G¹⁰⁰ and its rack and pinion releasing gear, as above identified, three cylinders $B\frac{1}{3}$ are here shown, fashioned integral from a single puppet-head housing B, and the whole disposed concentrically and at equal angular divergences (one hundred and twenty degrees) about the slide-bar guide axis thereof, which latter is a mere prismatic envelope B²⁰⁰ to the aforesaid square bar G¹⁰⁰, and the abutment member H¹⁰ in this case, being formed both integral and terminal upon the slide-bar G¹⁰⁰, has in its muzzle end G²⁰⁰ a conical drill or center socket-seat, in which the boring-bar F, having a similar conical shank F¹⁰, fits and chucks itself in a well-understood manner. The conduits $b' b^3$ are here, as more specifically shown in Fig. 2, presumably in connection with the several ram-cylinders' respective cavities, (indicated by broken outlines,) and their plunger-rams provided with proper pistons, as $g\frac{1}{3}$, for receiving the pressure both front and rear, are divested of rearward extensions, for the slide-bar G¹⁰⁰ is now guided independently of them by its envelope B²⁰⁰ aforesaid.

In Figs. 5, 6, 5^A, and 5^B I show certain modifications of the structure shown in Figs. 1 to 4, which adapt it to advance a boring-bar not only with a rectilinear reciprocation, but also to drive it with a rotary motion as well, the feed mechanism being, however, of the preferred screw-releasing sort, for here, with the exception of the omission of the bushing H

and the addition of cone-bearing F', Fig. 6, formed integral upon that portion of the bar where it emerges from the slide-bar's correspondingly bell-shaped or conic muzzle-cavity G³, and said conic cavity, the sliding members are correspondingly formed, located, and interguided in the cavity and glandular orifices of the puppet-housing to those shown and described in Figs. 1 to 4, inclusive, save that the puppet-housing B has, for the purpose of this modification, its rear part extended into a saddle-back extension B⁹, provided with a consecutively-disposed series of pillars $b^{10} b^{20} b^{30}$, having concentric cylindrical bearings $f' f^2 f^3$, Figs. 5 and 6, through the first two of which the longitudinally-slotted tail F² of the boring-bar F passes, its rear end F⁸ being connected to the flanged head h^{100} , Fig. 5^B, of the separate concentric releasing-screw H¹⁰⁰ by being screwed at F⁹ to the reducing-cap F¹⁰, whose annular flange F¹¹, embracing the neck of the screw H¹⁰⁰, prevents its escape from the chamber f^{10} , yet allows the bar to revolve when actuated, as hereinafter described, despite the fact that the spline-finger h^2 , bolted to the housing-pillar b^{30} of the head-extension B⁹, having its tip in the longitudinal slot h^3 of that screw, (see Figs. 5, 5^A, and 5^B,) prevents said screw from rotating at all, just as, on the other hand, the worm-threads of the nut L, registering with the screw H¹⁰⁰ and carried fixed to the, in this case, tubular spindle L' of said releasing-nut, may cause that screw to move endwise either to or away from the cylinder should that worm-nut be turned. Now this turning of the nut L, I have contrived in this case to depend upon mechanical connections with the mechanism now about to be described for giving the aforesaid rotary motion to the bar, by which the feed motion becomes automatic, as well as of the preferred releasing system sort--to wit, for the nut L, being here again provided with a worm-wheel and tangent screw, is substantially as shown in Figs. 1 to 4 above, save only that for convenience in association the said tangent screw is placed vertical instead of longitudinal, and its shaft k' , Fig. 5^A, being equipped with a longitudinally-splined miter-gear k^{10} , carries it normally just above where that shaft finds a step-bearing in the lower of the elbow-brackets b^{50} , a sufficient length of said spindle being preserved between said gear and the body of the tangent screw k (see Fig. 5^A) to permit of said gears being slid lengthwise along it, for if at any time it should be desired to put the automatic feed mechanism out of gear it then may be done by lifting the gear k^{10} aforesaid out of range of its normally-intermeshing miter-gear N', which latter is fixed upon the end of the counter-shaft N, and thence N, passing through bearings N²⁰ N³⁰, Fig. 6, fashioned from the side body of the head-housings extension B⁹, spans the gap between the pillars $b^{20} b^{10}$ and finds a steady bearing n^{15} in the adjoining side of the latter, and the whole lying parallel to and be-

low the parts $F H^{100}$ aforesaid carries, by means of their splined eyes engaging in the slot N^3 , (see Fig. 5,) the lengthwise-slidable change-of-speed spur-wheels $n n'$, which wheels, with the annularly-grooved slider-drum O , being fixed together or preferably formed integral, are controlled by the forked slider-rod n^3 , which, by a branch n^{13} , Fig. 6, passing within and across the extension B^9 , is operatively connected to slotted apertures b^8 by the collar n^5 and thumb-nut binding-screw at n^4 ; also, between the housing-bearings within b^{10} there is splined against radial slipping and fitted for mutual lengthwise sliding upon the bar F the sleeve M , (see Fig. 5, wherein the dotted outline M' is the spline fixed to said sleeve's eye, and F^2 the lengthwise-slotted seat in F , with which the same engage,) and fashioned integral with this sleeve M are two pinion-wheels $m m'$, adapted to engage and intermesh, respectively, with the aforesaid spur-gears $n n'$, according as one or the other of the latter is brought into alignment with its mate by the manipulation of the slide-rod n^3 , and there anchored by the nut at n^4 , the slot b^8 , Fig. 6, indicating by its length the range of action that is approximately necessary for this change of the driving-gear train. Finally, fixed to the shaft N and adjoining the gear n the miter-gear N^2 derives circular motion from the fellow intermeshing miter-gear V , to which such motion is in turn transmitted by the driving-shaft t , journaled transversely of the general structure in the lower portions of the pillar b^{10} , as indicated in the dotted bearings $t' t'$, Fig. 6, and so the same, preferably steadied by the outside hanger-bearing t^2 , carries the fast and loose belt-wheels $T T'$, by means of which the whole is operatively connected with or cut off at will from any suitable prime mover, for, as to the operation of this rotative automatically-feeding variety, it is only necessary that motive power be supplied the belt-wheel T in the usual way. Then that motion being transmitted by its shaft t , Fig. 6, the miter-gears $V N^2$ deliver it to the counter-shaft N , and it, either by $N m$ or n' , according to the position which the slider-bar n^3 places the slide-block O along the shaft N , serves to drive with correspondingly-modified speeds the sleeve M , which by its spline M' not only allows the boring-bar F to slide endwise through the bearings $b^{10} b^{20}$, but also drives it therein with a corresponding rotary motion, so that as the cone F^5 forms an abutment as well as the terminal journal of the rotary bar F , against which the muzzle G^3 of the ram-plunger slide-bar G bears, Fig. 6, it is thereby urged forward under the pressure of the liquid introduced through the conduit b^8 , and bar F is thus again, in addition to its newly-acquired rotary motion, subjected to a forward tendency similar to that which is received in the form illustrated in Figs. 1 to 4; but here the abutment b^{30} , Fig. 6, receiving the thrusts of the nut L , serves, through the

medium of the cap F^{10} and intermediate hold-back or releasing screw H^{100} , to either absolutely restrain that tendency and forbid the advance or to control it. The latter action takes effect at such time as the sliding miter-gear k^{10} is dropped into gear with $N' N'$, and thereby also derives motion from the shaft N , and so it, by means of the tangent screw and worm $k l$, rotates that nut in its sleeve-bearing L' . That accomplished, the screw H^{100} issues from the nut L , for, the spline-finger h^2 preventing that screw's rotation, the endwise pull delivered to its head h^{100} by the rotating cap F^{10} takes effect, and the spline finding no opposition in the slot to endwise sliding, the tendency is suffered to develop into an outward advance or "feed" of the bar, its rate of advance depending upon the pitch and rapidity of rotation of the screw and nut L , which are of course to be fashioned according to the exigencies of constructive detail.

It may also be noted that the binding-screw s (shown in Fig. 5^A) serves to hold the miter-gear k^{10} in or out of range of its fellow N' , as desired, and also that the slide-bar G is here also of the "hollow" type—that is, an open tube from end to end.

In conclusion, as to the operation of the several forms preceding Figs. 5 and 6 has been incidentally incorporated with the preceding description of their parts and mode of association, it need only be added here by way of supplement that while I prefer to employ my releasing feed mechanism in conjunction with the symmetrically and radially surrounding ram or rams of my improved boring-bar puppet mechanism, I do not wish to be thereby understood as solely limiting myself thereto, for, as above pointed out, whether the advance be merely a tendency, either absolutely restrained or automatically controlled and "fed" by the operation of parts such as are set forth in the descriptions of the releasing mechanism to Figs. 5 and 6 above, or whether that tendency be delivered immediately as developed to the bar, whereby it becomes both the feeding and advancing agency in one, all the several modifications hereinbefore described embody in common certain characteristics which, apart from that of the releasing mechanism, are novel to boring-bar puppets.

Having now described my invention, what I claim as new, and desire to secure by Letters Patent, is—

1. The combination, with a reciprocative puppet slide-bar and its puppet-housing, of a concentric and radially-surrounding hydraulic ram operative as a slide-bar-advancing mechanism, substantially as and for the purposes hereinbefore described.

2. The combination, with the puppet-housing and interguided reciprocating slide-bar, the latter provided with suitable means for carrying the shank of a boring-bar or equivalent instrument, of two or more symmetrical hydraulic rams disposed at equal angular di-

vergence about said slide-bar and operative to advance the same, substantially as and for the purposes hereinbefore described.

3. The combination, with the puppet-housing and hollow interguided reciprocative slide-bar, the latter provided with suitable means for carrying a boring-bar or equivalent instrument, of a hydraulic ram or rams radially disposed in a symmetrical arrangement about said slide-bar as well as operative to advance the same, substantially as and for the purposes hereinbefore described.

4. The combination, with a puppet-housing having a suitable cylinder-cavity and conduits leading thereto, of a reciprocative puppet slide-bar provided with means for carrying a boring-bar, said bar and ram-plunger fitted in said cylindrical cavity of said housing and operative to advance said slide-bar, the whole being radially and symmetrically disposed, substantially as and for the purposes hereinbefore described.

5. The combination, with a puppet-housing having a suitable cylinder-cavity and conduits leading thereto, of a reciprocating puppet slide-bar, and a ram-plunger formed integral and fitted to said cylinder so as to advance under hydraulic pressure, the whole being radially and symmetrically disposed, substantially as and for the purposes hereinbefore described.

6. The combination, with a hollow reciprocative slide-bar provided with a suitable abutment-bearing, as F⁵, and a boring-bar rotatably mounted therein, of a puppet-housing wherein said slide-bar may reciprocate endwise, mechanism for driving said boring-bar with a rotary motion, and a hydraulic ram or rams symmetrically and radially disposed to said slide-bar as well as operative to advance the same, substantially as and for the purposes hereinbefore described.

7. The combination, with the puppet-housing and interguided reciprocative slide-bar adapted to carry a boring-bar or equivalent in-

strument, of a radially and symmetrically disposed slide-bar-advancing mechanism consisting of a hydraulic ram or rams, and a holdback screw and nut or equivalent releasing mechanism operative to prohibit or control the tendency of said advancing mechanism, substantially as and for the purposes hereinbefore described.

8. The combination, with the puppet-housing and hollow interguided reciprocative slide-bar provided with a suitable abutment-bearing, as F⁵, of a boring-bar rotatably mounted therein, mechanism operative for driving said boring-bar with a rotary motion, symmetrically and radially disposed advancing mechanism consisting of a hydraulic ram or rams; and a holdback screw and nut or equivalent releasing mechanism operative to prohibit or control the tendency of said advancing mechanism to urge the slide-bar forward, substantially as and for the purposes hereinbefore described.

9. The combination, with the puppet-housing and hollow interguided reciprocative slide-bar provided with a suitable boring-bar abutment-bearing, as F⁵, of a boring-bar or equivalent instrument rotatably mounted therein, mechanism operative for driving said instrument with a rotary motion, symmetrically and radially disposed advancing mechanism consisting of a hydraulic ram or rams, a holdback screw and nut or equivalent releasing mechanism operative to prohibit or control the tendency of said advancing mechanism in urging the slide-bar forward, and mechanism, as the worm and tangent screw, operatively connecting said rotary driving mechanism with said releasing mechanism so as to automatically control the rate of said release, substantially as and for the purposes hereinbefore described.

FREDERICK W. TAYLOR.

Witnesses:

LEWIS R. DICK,
JOSHUA MATLACK, Jr.